

GrooveLine

SM[★]TOOLS[®]

TUNG^{HEAVY}GROOVE

www.tungaloy.com

Tungaloy Report No. 427-G

Effectively **reduces machining time!**

Member IMC Group
Tungaloy



Member IMC Group
Tungaloy



ACCELERATED MACHINING



GrooveLine

TUNG^{HEAVY}GROOVE

TUNGALOY



Unique system for wide grooving and wide profile grooving

Efficiently **reduces machining time** of wide width grooving and forming!

Effectively reduces the number of passes or machining time of complex profiles!

Easy insert clamp operated from front face

Indexing can be operated from front face of toolholder, reducing insert changing time and machine downtime.

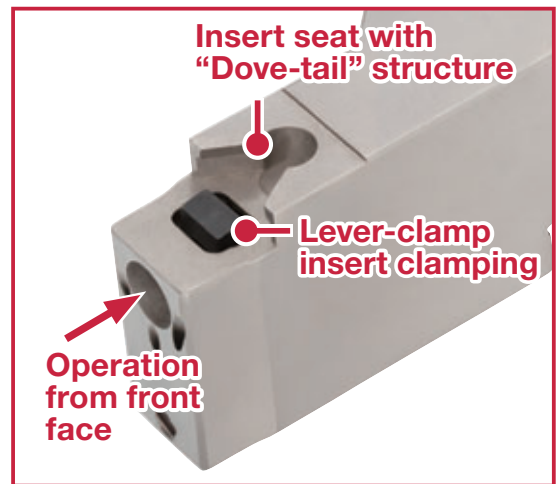

Highly rigid lever-clamping provides stable grooving

Dove-tail structure prevents insert movement during wide grooving operations.

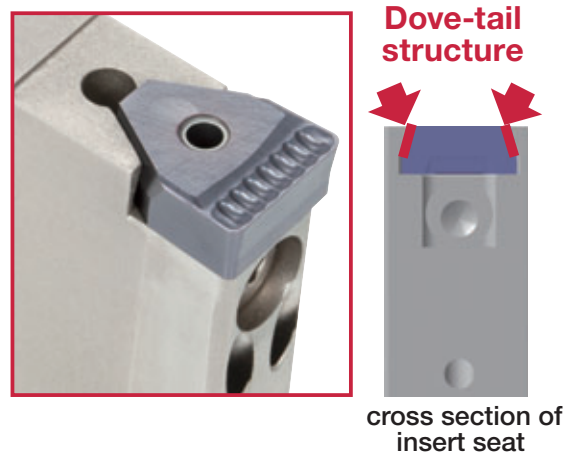

Open tool design, provides a clear path for chip evacuation

Excellent chip shape, due to the dimple shape chipbreaker design. Large rake angle reduces cutting forces.



Internal coolant supply is available (For FPGR type only)

Internal coolant supply can be added on the FPGR/L type grooving toolholders. 2 or 3 coolant holes on front face (depending on toolholder size). Coolant is supplied directly to the cutting edge, reducing flank wear and improving tool life, as well as improves chip control.

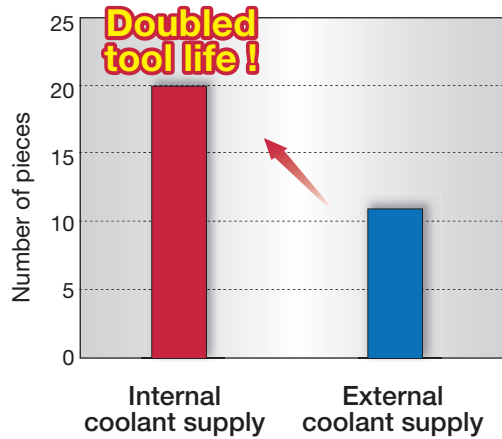
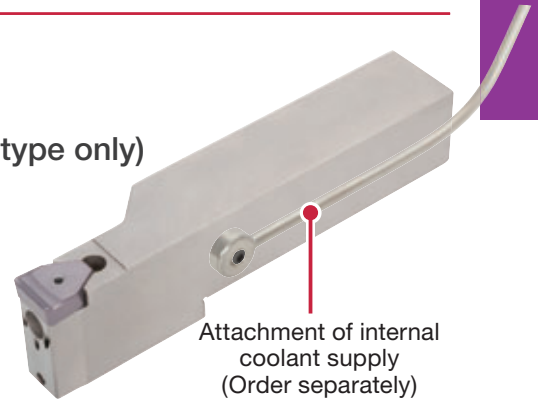

Insert	: PSGM10-08
Grade	: AH725
Work material	: SCM415
Cutting speed	: $V_c = 100$ m/min
Feed	: $f = 0.3$ mm/rev
Groove depth	: $d = 20$ mm

Profile grooving inserts and tools

- Inserts are supplied in width (W) 10 - 25 mm.
- The insert length is extended for profile shapes up to 5.5 mm depth.

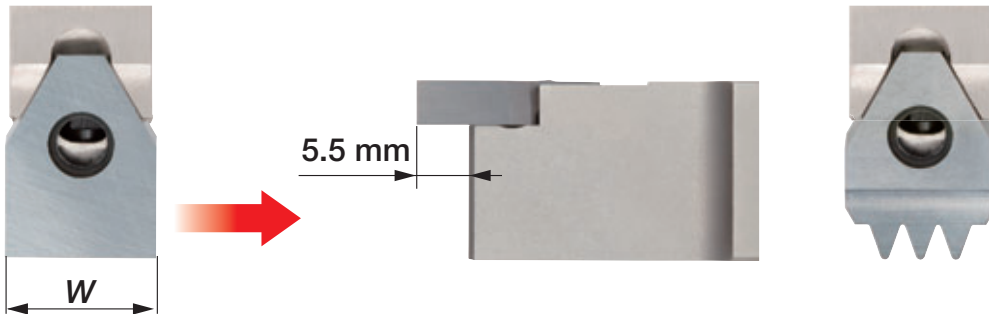

Two styles of tools are available!

■ Lever lock type

■ Screw on type

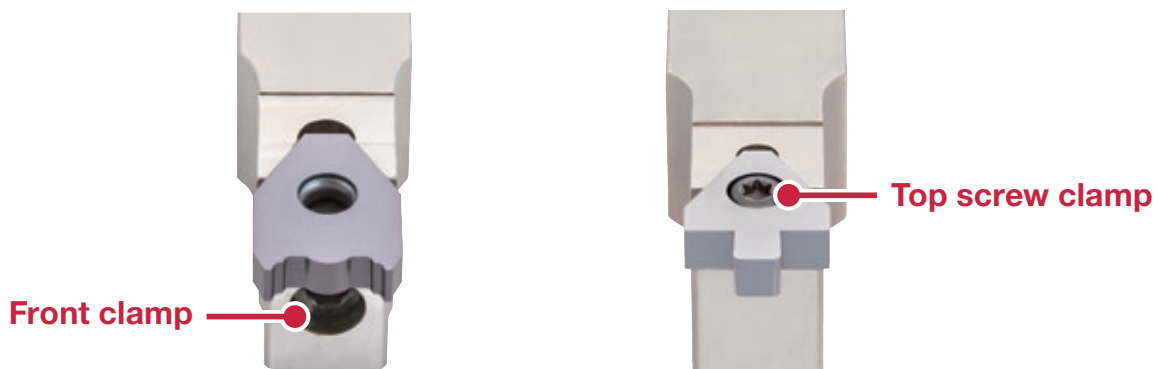

Inserts

■ For wide grooving



	Groove width W^* (mm)	Cat. No.	Grades		Dimensions (mm)		
			Coated		L	s	r_{ϵ}
			AH725				
	10	PSGM10-08	●		11	4.0	0.8
	15	PSGM15-15	●		15	5.0	1.5
	20	PSGM20-20	●		22	6.5	2.0
	25	PSGM25-20	●		22	6.5	2.0

* Tolerance of groove width $W = 10: \pm 0.08, W \geq 15: \pm 0.1$

■ Blanks for wide profile grooving*



	Groove width $W \pm 0.025$ (mm)	Cat. No.	Grades		Dimensions (mm)	
			Carbide		L	s
			UX30	TH10		
	10.2	PSGB10	●	●	18	4.0
	15.2	PSGB15	●	●	20	5.0
	20.2	PSGB20	●	●	27	6.5
	25.2	PSGB25	●	●	27	6.5

*Stocked products are blanks (semi-finished) for formed inserts

Toolholders

FPG R

Lever lock type, for external wide grooving

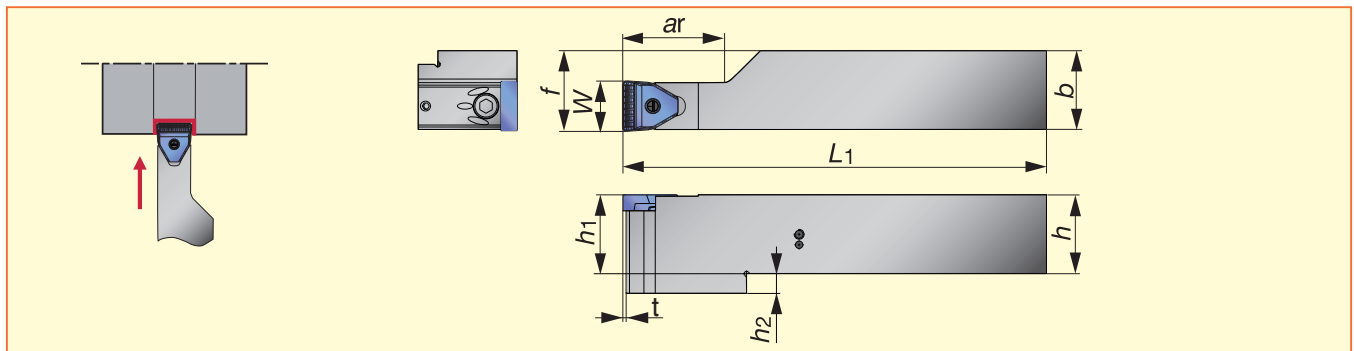

Groove width W (mm)	Cat. No.	Stock	Max. groove depth ar (mm)		Dimensions (mm)								Clamping screw (*) Insert	Lever Spring Wrench	
			PSGB	PSGM	h_1	b	h	L_1		f	h_2	t			
								PSGB	PSGM			PSGB			PSGM
10	FPGR2525M-10T20	●	25	20	25	25	25	155	150	25.5	-	5.5	0.5	PSG*10	FCS3 FCL4 BP-5 P-2.5
10	FPGR3232P-10T36	●	41	36	32	32	32	175	170	32.5	-	5.5	0.5	PSG*10	FCS3 FCL4 BP-5 P-2.5
15	FPGR2525M-15T20	●	25	20	25	25	25	155	150	25.5	-	5.5	0.5	PSG*15	FCS3 FCL4 BP-5 P-2.5
15	FPGR3232P-15T40	●	45	40	32	32	32	175	170	32.5	-	5.5	0.4	PSG*15	FCS3 FCL4 BP-5 P-2.5
20	FPGR3232P-20T40	●	45	40	32	32	32	175	170	32.5	8	5.5	0.4	PSG*20	FCS6 FCL8 BP-9 P-5
20	FPGR4040R-20T50	●	55	50	40	40	40	205	200	40.5	8	5.5	0.4	PSG*20	FCS6 FCL8 BP-9 P-5
25	FPGR3232P-25T40	●	45	40	32	32	32	175	170	32.5	8	5.5	0.4	PSG*25	FCS6 FCL8 BP-9 P-5
25	FPGR4040R-25T50	●	55	50	40	40	40	205	200	40.5	8	5.5	0.4	PSG*25	FCS6 FCL8 BP-9 P-5

(*) Can be used with both wide grooving and profile grooving inserts

● : Stocked items

FPGN

Lever lock type, for external wide profile grooving

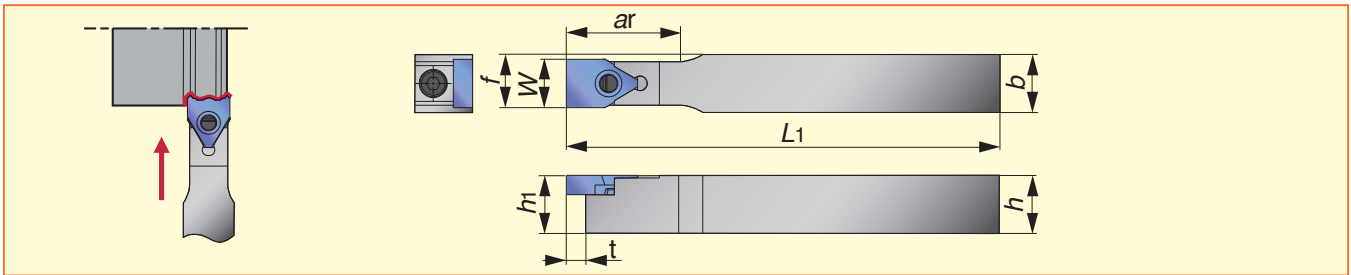

Groove width W (mm)	Cat. No.	Stock	Max. groove depth ar (mm)		Dimensions (mm)							Insert	Clamping screw	Lever	Spring	Wrench	
			PSGB	PSGM	h ₁	b	h	L ₁		f	t						
								PSGB	PSGM		PSGB						PSGM
10	FPGN1212X-10T20	●	25	20	12	12	12	125	120	11.0	5.5	0.5	PSG*10	FCS3	FCL4	BP-5	P-2.5
10	FPGN1616X-10T20	●	25	20	16	16	16	125	120	13.0	5.5	0.5	PSG*10	FCS3	FCL4	BP-5	P-2.5
10	FPGN2020K-10T20	●	25	20	20	20	20	130	125	15.0	5.5	0.5	PSG*10	FCS3	FCL4	BP-5	P-2.5
15	FPGN1616X-15T25	●	30	25	16	16	16	125	120	15.5	5.5	0.4	PSG*15	FCS3	FCL4	BP-5	P-2.5
15	FPGN2020K-15T25	●	30	25	20	20	20	130	125	17.5	5.5	0.4	PSG*15	FCS3	FCL4	BP-5	P-2.5
20	FPGN2020K-20T32	●	37	32	20	20	20	130	125	20.0	5.5	0.4	PSG*20	FCS6	FCL8	BP-9	P-5
20	FPGN2525M-20T32	●	37	32	25	25	25	155	150	22.5	5.5	0.4	PSG*20	FCS6	FCL8	BP-9	P-5
25	FPGN2525M-25T36	●	41	36	25	25	25	155	150	25.0	5.5	0.4	PSG*25	FCS6	FCL8	BP-9	P-5

(*1) Can be used with both wide grooving and profile grooving inserts

SPGN

Screw on type, for external wide profile grooving

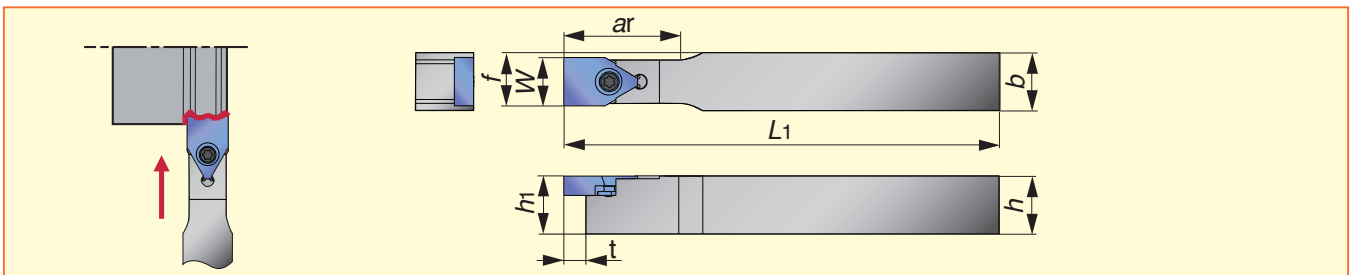

Groove width W (mm)	Cat. No.	Stock	Max. groove depth ar(mm)	Dimensions (mm)						Insert	Clamping screw	Wrench
				h ₁	b	h	L ₁	f	t			
10	SPGN1212X-10T20	●	25	12	12	12	125	11.0	5.5	PSGB10	CSTB-3L081	T-9F
10	SPGN1616X-10T20	●	25	16	16	16	125	13.0	5.5	PSGB10	CSTB-3L081	T-9F
10	SPGN2020K-10T20	●	25	20	20	20	130	15.0	5.5	PSGB10	CSTB-3L081	T-9F
15	SPGN1616X-15T25	●	30	16	16	16	125	15.5	5.5	PSGB15	CSTB-4	T-15F
15	SPGN2020K-15T25	●	30	20	20	20	130	17.5	5.5	PSGB15	CSTB-4	T-15F
20	SPGN2020K-20T32	●	37	20	20	20	130	20.0	5.5	PSGB20	CSTB-5	T-20F
20	SPGN2525M-20T32	●	37	25	25	25	155	22.5	5.5	PSGB20	CSTB-5	T-20F
25	SPGN2525M-25T36	●	41	25	25	25	155	25.0	5.5	PSGB25	CSTB-5	T-20F

(*2) Can be used with profile grooving inserts, only

● : Stocked items

■ Spare parts for internal coolant supply attachment (Order separately)

No.	Parts name	Designation	Note
①	Body	FPGR...	-
②	Insert	PSGM...	-
③	Coolant supply attachment	SGCU 341	-
④	Connector	Commercial items can be used	G 1/8 thread NPT 1/8 thread

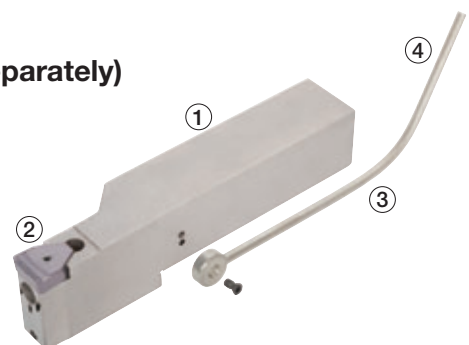

Grades



Wide grooving insert PSGM type

AH725



Steel

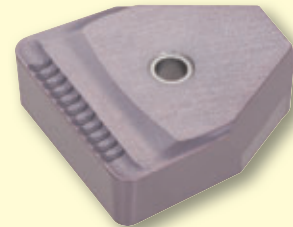

Recommended grade for grooving.

PVD coated grade featuring an excellent balance of strength and wear resistance.

- The combination of micro grain substrate and flash-coating with high heat resistance provides incredible performance in wide grooving.



Forming insert PSGB type

UX30

Uncoated



Steel



Stainless

TH10

Uncoated



Cast Iron



Non-ferrous

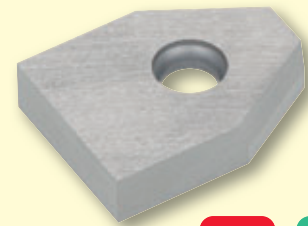

Cemented carbide grade with high fracture resistance.

Carbide grade for general purpose with excellent wear resistance.

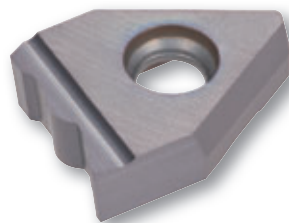

Specially tailored profile insert

Standard cutting conditions



Wide grooving

ISO	Workpiece materials	Hardness (HB)	Grade	Cutting speed Vc (m/min)
P	Alloy steels (SCM440 / 42CrMo4 etc.)	< 300	AH725	50 - 180
	Alloy steels (SCM440 / 42CrMo4 etc.)	< 300	UX30	50 - 120
PSGM type insert	Groove width: W (mm)			
	10	15	20	25
Feed: f (mm/rev)	0.2 - 0.4	0.2 - 0.4	0.3 - 0.5	0.3 - 0.5

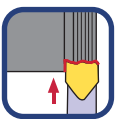

Forming

ISO	Workpiece materials	Hardness (HB)	Grade	Cutting speed Vc (m/min)
P	Steels (S45C / C45 etc.)	< 200	UX30	50 - 150
	Alloy steels (SCM440 / 42CrMo4 etc.)	< 300	UX30	50 - 120
M	Stainless steels (SUS303 / X10CrNiS18-9 etc.)	< 200	UX30	50 - 120
K	Grey cast irons (FC250 / 250 etc.)	-	TH10	50 - 150
	Ductile cast irons (FCD450 / 450-10S etc.)	-	TH10	50 - 120
N	Aluminium alloy (Si < 12% etc.)	-	TH10	100 - 500

- Custom shaped inserts can be supplied on customer's request, according to the designated final shape on part drawing.
- Semi-finished blanks PSGB types are offered for purchase.

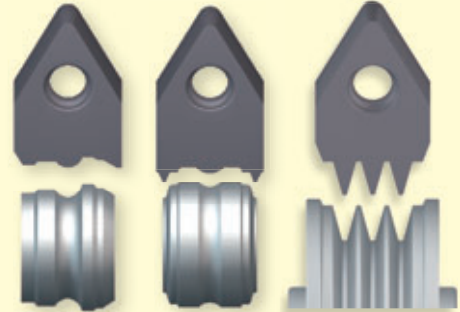

Practical examples

Workpiece type		Machine part	Engine part
Toolholder		FPGR3232P-10T36	FPGR3232P-10T36
Insert		PSGM10-08 (W = 10 mm)	PSGM10-08 (W = 10 mm)
Grade		AH725	AH725
Workpiece material		SCM415	Cast steel
Cutting conditions			
Cutting conditions	Cutting speed: Vc (m/min)	110	65
	Feed : f (mm/rev)	0.3	0.37
	Number of pass for 1 groove	2	3
	Method of machining	Grooving	Grooving
	Coolant	Wet	Wet
Results		<p>TUNGROOVE Competitor</p> <p>By using wider grooving tool, cycle times can be reduced to 1/3. 15 times longer tool life is achieved due to AH725 grade with high wear resistance.</p>	<p>TUNGROOVE Competitor</p> <p>Higher cutting conditions and continuous feeds without pecking cycles, drastically reduce machining times.</p>



Tungaloy Corporation (Head office)

11-1 Yoshima-Kogyodanchi
Iwaki-city, Fukushima, 970-1144 Japan
Phone: +81-246-36-8501
Fax: +81-246-36-8542
www.tungaloy.co.jp

Tungaloy America, Inc.

3726 N Ventura Drive
Arlington Heights, IL 60004, U.S.A.
Phone: +1-888-554-8394
Fax: +1-888-554-8392
www.tungaloyamerica.com

Tungaloy Canada

432 Elgin St. Unit 3
Brantford, Ontario N3S 7P7, Canada
Phone: +1-519-758-5779
Fax: +1-519-758-5791
www.tungaloy.co.jp/ca

Tungaloy de Mexico S.A.

C Los Arellano 113,
Parque Industrial Siglo XXI
Aguascalientes, AGS, Mexico 20290
Phone: +52-449-929-5410
Fax: +52-449-929-5411
www.tungaloy.co.jp/mx

Tungaloy do Brasil Ltda.

Avd. Independencia N4158 Residencial Flora
13280-000 Vinhedo, São Paulo, Brasil
Phone: +55-19-38262757
Fax: +55-19-38262757
www.tungaloy.com/br

Tungaloy Germany GmbH

An der Alten Ziegelei 1
D-40789 Monheim, Germany
Phone: +49-2173-90420-0
Fax: +49-2173-90420-19
www.tungaloy.de

Tungaloy France S.A.S.

ZA Courtaboeuf - Le Rio
1 rue de la Terre de feu
F-91952 Courtaboeuf Cedex, France
Phone: +33-1-6486-4300
Fax: +33-1-6907-7817
www.tungaloy.fr

Tungaloy Italia S.r.l.

Via E. Andolfato 10
I-20126 Milano, Italy
Phone: +39-02-252012-1
Fax: +39-02-252012-65
www.tungaloy.it

Tungaloy Czech s.r.o.

Turanka 115
CZ-627 00 Brno, Czech Republic
Phone: +420-532 123 391
Fax: +420-532 123 392
www.tungaloy.cz

Tungaloy Ibérica S.L.

C/Miquel Servet, 43B, Nau 7
Pol. Ind. Bufalvent
ES-08243 Manresa (BCN), Spain
Phone: +34 93 113 1360
Fax: +34 93 876 2798
www.tungaloy.es

Tungaloy Scandinavia AB

Bultgatan 38
442 40 Kungälv, Sweden
Phone: +46-462119200
www.tungaloy.se

Tungaloy Rus, LLC

36-D Harkovsky Lane
308009 Belgorod, Russia
Phone: +7 4722 24 00 07
Fax: +7 4722 24 00 08
www.tungaloy.co.jp/ru

Tungaloy East LLC

Stachek str., h.4, office 2, Ekaterinburg,
620017, Russia
Phone: +7-343-389-13-22
Fax: +7-343-278-94-35
www.tungaloy.co.jp/rue

Tungaloy Polska Sp. z o.o.

ul. Genewska 24
03-963 Warszawa, Poland
Phone: +48-22-617-0890
Fax: +48-22-617-0890
www.tungaloy.co.jp/pl

Tungaloy U.K. Ltd

The Technology Centre,
Wolverhampton Science Park
Glaisher Drive, Wolverhampton
West Midlands WV10 9RU, UK
Phone: +44 121 4000 231
Fax: +44 121 270 9694
www.tungaloy.co.jp/uk
salesinfo@tungaloyuk.co.uk

Tungaloy Hungary Kft

Erzsébet királyné útja 125
H-1142 Budapest, Hungary
Phone: +36 1 781-6846
Fax: +36 1 781-6866
www.tungaloy.co.jp/hu
info@tungaloytools.hu

Tungaloy Turkey

Dudullu.OSB 4. Cad No:4
34776 Umraniye Istanbul, TURKEY
Phone: +90 216 540 04 67
Fax: +90 216 540 04 87
www.tungaloy.com.tr
info@tungaloy.com.tr

Tungaloy Benelux b.v.

Tjalk 70
NL-2411 NZ Bodegraven, Netherlands
Phone: +31 172 630 420
Fax: +31 172 630 429
www.tungaloy-benelux.com

Tungaloy Croatia

Josipa Kozarca 4
10432 Bregana, Croatia
Phone: +385 1 3326 604
Fax: +385 1 3327 683
www.tungaloy.hr

Tungaloy Cutting Tool (Shanghai) Co.,Ltd.

Rm No 401 No.88 Zhabei
Jiangchang No.3 Rd
Shanghai 200436, China
Phone: +86-21-3632-1880
Fax: +86-21-3621-1918
www.tungaloy.co.jp/tcts

Tungaloy Cutting Tool (Thailand) Co.,Ltd.

Interlink tower 4th Fl.
1858/5-7 Bangna-Trad Road
km.5 Bangna, Bangna, Bangkok 10260
Thailand
Phone: +66-2-751-5711
Fax: +66-2-751-5715
www.tungaloy.co.th

Tungaloy Singapore (Pte.), Ltd.

62 Ubi Road 1, #06-11 Oxley BizHub 2
Singapore 408734
Phone: +65-6391-1833
Fax: +65-6299-4557
www.tungaloy.co.jp/tspl

Tungaloy Vietnam

Unit 18, 4th Fl. Saigon Centre Building
65 Le Loi Blvd.
Dist 1, Ho Chi Minh City, Vietnam
Phone: +84-8-3827-0201
Fax: +84-8-3827-0203
www.tungaloy.co.jp/tspl

Tungaloy India Pvt. Ltd.

Indiabulls Finance Centre,
Unit # 902-A, 9th Floor,
Tower 1, Senapati Bapat Marg,
Elphinstone Road (West),
Mumbai-400013, India
Phone: +91-22-6124-8804
Fax: +91-22-6124-8899
www.tungaloy.co.jp/in

Tungaloy Korea Co., Ltd

#1312, Byucksan Digital Valley 5-cha
Beotkkot-ro 244, Geumcheon-gu
153-788 Seoul, Korea
Phone: +82-2-2621-6161
Fax: +82-2-6393-8952
www.tungaloy.co.jp/kr

Tungaloy Malaysia Sdn Bhd

50 K-2, Kelana Mall, Jalan SS6/14
Kelana Jaya, 47301
Petaling Jaya, Selangor Darul Ehsan
Malaysia
Phone: +603-7805-3222
Fax: +603-7804-8563
www.tungaloy.co.jp/my

Tungaloy Australia Pty Ltd

PO Box 2232, Rowville,
Victoria 3178, Australia
Phone: +61-3-9755-8147
Fax: +61-3-9755-6070
www.tungaloy.com.au

PT. Tungaloy Indonesia

Kompleks Grand Wisata Block AA-10 No.3-5
Cibitung
Bekasi 17510, Indonesia
Phone: +62-21-8261-5808
Fax: +62-21-8261-5809
www.tungaloy.co.jp/id

Schnyder + Minder AG | Zielmattenring 11 | CH-4563 Gerlafingen | Phone: +41 31 832 77 00 | info@smtools.ch | www.smtools.ch

Distributed by:



DOWNLOAD
Dr. Carbide App



Available on the
App Store



GET IT ON
Google play



AS9100 Certified
78006
2015.11.04
ISO14001 Certified
EC97J1123
1997.11.26